

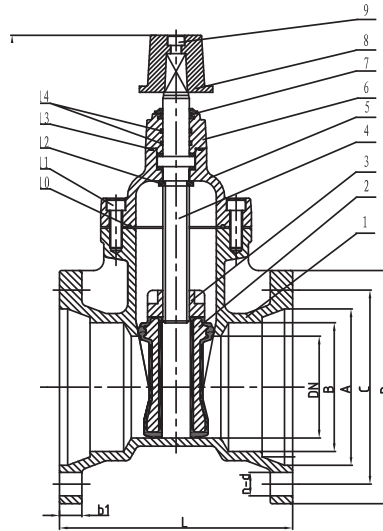

AWWA C515 Mechanical Joint Resilient NRS Gate Valve(JQZ35XQ)



MATERIAL SPECIFICATION

Part NO.	PART	Standard Specification	Options
1	BODY	ASTM A536.65-45-12	
2	WEDGE	ASTM A536.65-45-12+EPDM	ASTM A536.65-45-12+NBR
3	STEM NUT	Brass	Bronze
4	STEM	Al Si420	AISI304, AISI316, AISI 431, AISI-bronze
5	BONNET	ASTM A536.65-45-12	
6	GLAND	ASTM A536.65-45-12	
7	DUST PROOF	NBR	EPDM
8	OPERATE NUT	ASTM A536.65-45-12	
9	BOLT	Carbon Steel Zinc Plated	ANSI304, SNSI316
10	GASKET	NBR	EPDM
11	BOLTS	Carbon Steel Zinc Plated	ANSI304, SNSI316
12	BUSH	NBR	EPDM
13	O RING	NBR	EPDM
14	O RING	NBR	EPDM

Note: For special material request other than standard specification, please indicate clearly on the inquiry or order list.

- Connection Ends: Mechanical Joint to ANSI/AWWA C153/A21.53
- Working Pressure: 250PSI
- Temperature Range: 0°C- 80°C
- Coating: Fusion Bonded Epoxy Coating in accordance with ANSI/AWWA C550

SIZE	Dimensions(Inch)							
	L1	H	C	B	D	n-Φd	A	b1
2"	8.27	10.59	4.74	2.66	6.19	2-0.75	3.54	0.59
3"	7.99	12.20	6.19	4.07	7.68	4-0.75	4.94	0.63
4"	9.02	13.78	7.50	4.90	9.02	4-0.75	6.02	0.75
6"	10.51	18.98	9.50	7.01	11.10	6-0.87	8.13	0.89
8"	11.50	20.47	11.75	9.15	13.39	6-0.87	10.28	1.00
10"	12.99	24.88	14.00	11.20	15.63	8-0.87	12.34	1.00
12"	14.02	29.33	16.26	13.31	17.87	8-0.87	14.45	1.00
14"	15.00	32.87	18.75	15.45	20.28	10-0.87	16.56	1.25
16"	15.98	37.52	21.00	17.55	22.50	12-0.87	18.66	1.31
18"	17.01	41.34	23.25	19.65	25.12	12-0.87	20.75	1.38
20"	17.99	45.67	25.50	21.75	26.97	14-0.87	22.85	1.44
24"	20.00	54.92	30.00	25.94	31.50	16-0.87	27.05	1.57
36"	27.99	73.03	43.76	38.48	46.00		39.76	2.00

