

AWWA C509 Flanged Resilient NRS Gate Valve With Wrench Nut & Gearbox & Bypass 250PSI (JHZ45XC-GB)

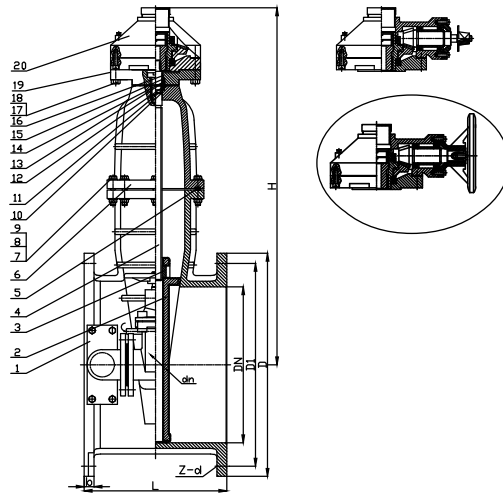

MATERIAL SPECIFICATION

Part No.	Description	Material Specification	Options
1	Body	Ductile Iron ASTM A536	
2	Wedge	DI ASTM A536 +EPDM ASTM D2000	
3	Stem Nut	Brass ASTM B16	
4	Stem	Stainless Steel SS316	Stainless Steel 304/Brass
5	Gasket	EPDM ASTM D2000	
6	Bonnet	Ductile Iron ASTM A536	
7	Bonnet Bolt	Stainless Steel SS316	Stainless Steel 304
8	Nut	Stainless Steel SS316	Stainless Steel 304
9	Washer	Stainless Steel SS316	Stainless Steel 304
10	O-Ring	EPDM ASTM D2000	
11	Minipad	14-24" PTFE	
	Bearing	30-48" Stainless Steel SS316	
12	O-Ring	EPDM ASTM D2000	
13	O-Ring	EPDM ASTM D2000	
14	Seal Ring	Brass ASTM B16	
15	O-Ring	EPDM ASTM D2000	
16	Dust Ring	EPDM ASTM D2000	
17	Bolt	Stainless Steel SS316	Stainless Steel 304
18	Washer	Stainless Steel SS316	Stainless Steel 304
19	Gland	Ductile Iron ASTM A536	
20	Gear Box		

- Connection Ends: Flange to ASME B16.1 CL 125 / ASME B16.42 CL150
- Working Pressure: 250PSI
- Temperature Range: 32 -176
- Coating: Fusion Bonded Epoxy Coating in accordance with ANSI/AWWA C550
- All JHZ series can be equipped with Gearbox.

Note:For special material request other than standard specification,please indicate clearly on the inquiry or order list.

ITEM NO.	Dimensions(Inch)								
	Size	D	D1	b	z	d	L	H	dn
JHZ45XC-GB14	14"	21.00	18.75	1.38	12	1.125	15.00	36.73	1.5"
JHZ45XC-GB16	16"	23.50	21.25	1.44	16	1.125	16.00	39.76	1.5"
JHZ45XC-GB18	18"	25.00	22.75	1.56	16	1.250	17.00	42.87	1.5"
JHZ45XC-GB20	20"	27.50	25.00	1.69	20	1.250	18.00	45.98	1.5"
JHZ45XC-GB24	24"	32.00	29.50	1.88	20	1.375	20.00	52.28	2"
JHZ45XC-GB30	30"	38.75	36.00	2.12	28	1.375	24.00	60.24	3"
JHZ45XC-GB36	36"	46.00	42.75	2.38	32	1.625	28.00	65.94	3"
JHZ45XC-GB42	42"	53.00	49.50	2.62	36	1.625	36.00	76.77	4"
JHZ45XC-GB48	48"	59.50	56.00	2.75	44	1.625	44.00	82.68	4"