

# AWWA C515 Mechanical Joint Resilient NRS Gate Valve with Post Plate 300PSI (JKDZ45MPF)

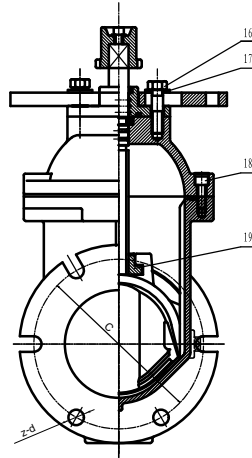
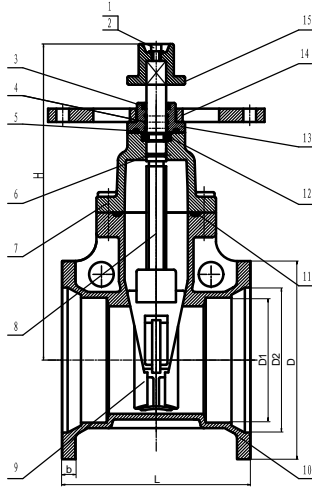

JKDZ45MPF

## MATERIAL SPECIFICATION

PART NO.	Description	Material Specification	Options
1	Flat Washer	Stainless Steel 304	Stainless Steel 316
2	Hexagon Socket Screw	Stainless Steel 304	Stainless Steel 316
3	Sealing Ring	EPDM ASTM D2000	
4	O-Ring	EPDM ASTM D2000	
5	Sealing Ring	EPDM ASTM D2000	
6	O-Ring	EPDM ASTM D2000	
7	Bonnet	Ductile Iron ASTM A536	
8	Stem	Stainless Steel 304	Stainless Steel 316
9	Disc	EPDM ASTM D2000 +DI ASTM A536	
10	Body	Ductile Iron ASTM A536	
11	Sealing Ring	EPDM ASTM D2000	
12	Retaining Ring	ASTM B148 C95400	
13	Gland	Ductile Iron ASTM A536	
14	Post Plate	Ductile Iron ASTM A536	
15	Wrench Nut	Ductile Iron ASTM A536	
16	Bolt	Stainless Steel 304	Stainless Steel 316
17	Washer	Stainless Steel 304	Stainless Steel 316
18	Hexagon Socket Screw	Stainless Steel 304	Stainless Steel 316
19	Stem Nut	ASTM B148 C95400	



JKDZ45M

Note: For special material request other than standard specification, please indicate clearly on the inquiry or order list.

Item No.	Dimensions(Inch)									
	Size	D	C	D1	D2	b	z	d	L	H
JKDZ45MPF03	3"	7.69	6.19	4.06	4.94	0.75	4	0.750	8.00	12.68
JKDZ45MPF04	4"	9.12	7.50	4.90	6.02	0.75	4	0.875	9.00	13.46
JKDZ45MPF06	6"	11.12	9.50	7.00	8.12	0.75	6	0.875	10.50	17.64
JKDZ45MPF08	8"	13.37	11.75	9.15	10.27	0.88	6	0.875	11.50	21.02
JKDZ45MPF10	10"	15.69	14.00	11.20	12.34	0.94	8	0.875	13.00	25.00
JKDZ45MPF12	12"	17.94	16.25	13.30	14.44	1.00	8	0.875	14.00	28.35

- Connection Ends: Mechanical Joint to ANSI/AWWA C153/A21.53/ ANSI/AWWA C110/A21.10
- Working Pressure: 300PSI
- Temperature Range: 32°F -176°F
- Coating: Fusion Bonded Epoxy Coating in accordance with ANSI/AWWA C550