

AWWA C515 Flanged x Mechanical Joint Resilient NRS Gate Valve with Post Plate 300PSI (JKDZ45FMPF)

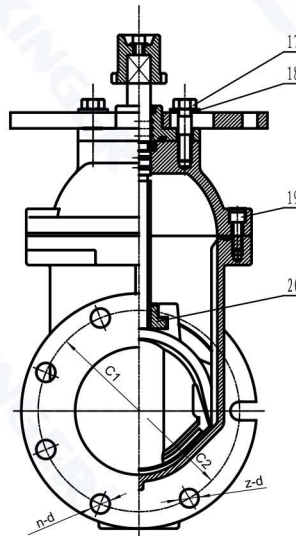

JKDZ45FMPF

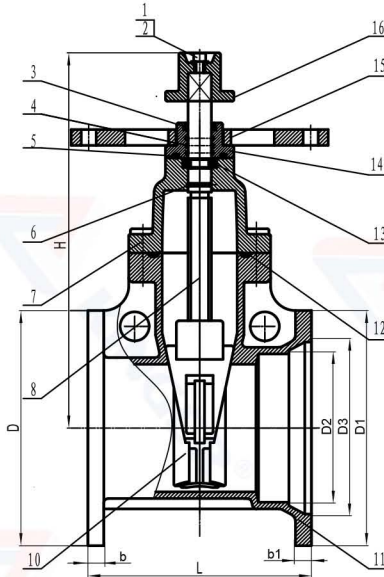

JKDZ45FM

MATERIAL SPECIFICATION

PART NO.	Description	Material Specification	Options
1	Flat Washer	Stainless Steel 304	Stainless Steel 316
2	Hexagon Socket Screw	Stainless Steel 304	Stainless Steel 316
3	Sealing Ring	EPDM ASTM D2000	
4	O-Ring	EPDM ASTM D2000	
5	Sealing Ring	EPDM ASTM D2000	
6	O-Ring	EPDM ASTM D2000	
7	Bonnet	Ductile Iron ASTM A536	
8	Stem	Stainless Steel 304	Stainless Steel 316
10	Disc	EPDM ASTM D2000 +DI ASTM A536	
11	Body	Ductile Iron ASTM A536	
12	Sealing Ring	EPDM ASTM D2000	
13	Retaining Ring	ASTM B148 C95400	
14	Gland	Ductile Iron ASTM A536	
15	Post Plate	Ductile Iron ASTM A536	
16	Wrench Nut	Ductile Iron ASTM A536	
17	Bolt	Stainless Steel 304	Stainless Steel 316
18	Washer	Stainless Steel 304	Stainless Steel 316
19	Hexagon Socket Screw	Stainless Steel 304	Stainless Steel 316
20	Stem Nut	ASTM B148 C95400	

Note: For special material request other than standard specification, please indicate clearly on the inquiry or order list.

Item No.	Size	Dimensions(Inch)													
		Flange					Mechanical							L	H
		D	C1	b	n	d	D1	C2	D2	D3	b1	z	d		
JKDZ45FMPF03	3"	7.50	6.00	0.75	4	0.750	7.69	6.19	4.06	4.94	0.75	4	0.750	8.00	12.68
JKDZ45FMPF04	4"	9.00	7.50	0.94	8	0.750	9.12	7.50	4.90	6.02	0.75	4	0.875	9.00	13.46
JKDZ45FMPF06	6"	11.00	9.50	1.00	8	0.875	11.12	9.50	7.00	8.12	0.75	6	0.875	10.50	17.64
JKDZ45FMPF08	8"	13.50	11.75	1.12	8	0.875	13.37	11.75	9.15	10.27	0.88	6	0.875	11.50	21.02
JKDZ45FMPF10	10"	16.00	14.25	1.19	12	1.000	15.69	14.00	11.20	12.34	0.94	8	0.875	13.00	25.00
JKDZ45FMPF12	12"	19.00	17.00	1.25	12	1.000	17.94	16.25	13.30	14.44	1.00	8	0.875	14.00	28.35

- Connection Ends: Flange to ASME B16.1 CL 125 / ASME B16.42 CL150
Mechanical Joint to ANSI/AWWA C153/A21.53 / ANSI/AWWA C110/A21.10
- Working Pressure: 300PSI
- Temperature Range: 32°F -176°F
- Coating: Fusion Bonded Epoxy Coating in accordance with ANSI/AWWA C550

