

AWWA C515 Grooved Resilient NRS Gate Valve 300PSI (JKDZ85-300A)

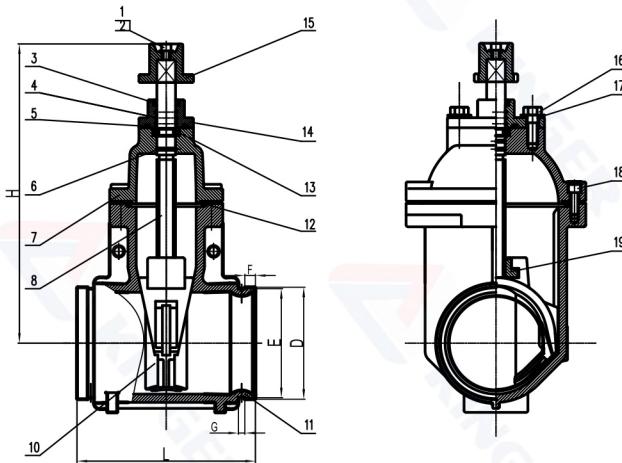

JKDZ85-300A



JKDZ85GRPF

MATERIAL SPECIFICATION

PART NO.	Description	Material Specification	Options
1	Flat Washer	Stainless Steel 304	Stainless Steel 316
2	Hexagon Socket Screw	Stainless Steel 304	Stainless Steel 316
3	Seal Ring	EPDM ASTM D2000	
4	O-Ring	EPDM ASTM D2000	
5	Seal Ring	EPDM ASTM D2000	
6	O-Ring	EPDM ASTM D2000	
7	Bonnet	Ductile Iron ASTM A536	
8	Stem	Stainless Steel 304	Stainless Steel 316
10	Disc	EPDM ASTM D2000 +DI ASTM A536	
11	Body	Ductile Iron ASTM A536	
12	Seal Ring	EPDM ASTM D2000	
13	Retaining Ring	ASTM B148 C95400	
14	Gland	Ductile Iron ASTM A536	
15	Wrench Nut	Ductile Iron ASTM A536	
16	Bolt	Stainless Steel 304	Stainless Steel 316
17	Washer	Stainless Steel 304	Stainless Steel 316
18	Hexagon Socket Screw	Stainless Steel 304	Stainless Steel 316
19	Stem Nut	ASTM B148 C95400	

Note: For special material request other than standard specification, please indicate clearly on the inquiry or order list.

Item No.	Dimensions(Inch)						
	Size	D	E	F	G	L	H
JKDZ85-300A025	2.5"	2.875	2.720	0.625	0.312	7.50	11.50
		2.996	2.845				
JKDZ85-300A03	3"	3.500	3.344	0.625	0.312	8.00	12.68
JKDZ85-300A04	4"	4.500	4.334	0.625	0.375	9.00	13.46
JKDZ85-300A05	5"	5.500	5.334	0.625	0.375	10.00	16.22
		5.563	5.395				
JKDZ85-300A06	6"	6.500	6.335	0.625	0.375	10.50	17.64
		6.625	6.455				
JKDZ85-300A08	8"	8.625	8.441	0.750	0.438	11.50	21.02
JKDZ85-300A10	10"	10.750	10.562	0.750	0.500	13.00	25.00
JKDZ85-300A12	12"	12.750	12.531	0.750	0.500	14.00	28.35

- Connection Ends: Groove to AWWA C606/ ISO 6182
- Working Pressure: 300PSI
- Temperature Range: 32°F-176°F
- Coating: Fusion Bonded Epoxy Coating in accordance with ANSI/AWWA C550